

REGULAR WOOD SINGLE SHEAVE BLOCK

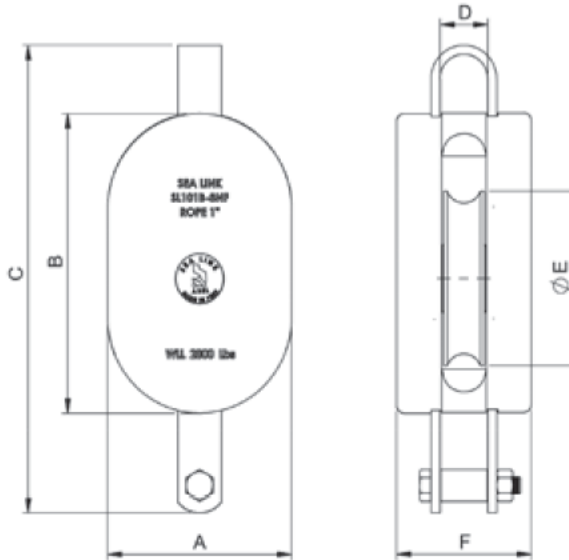

NO FITTING (NF)



SHACKLE (S)



SWIVEL HOOK (SH)



FIXED HOOK (H)

MODEL NO.	WLL LBS	ROPE ØR	DIMENSIONS (MM)						WEIGHT (LBS)			
			A	B	C	D	ØE	F	S SHACKLE	SH SWIVEL HOOK	H FIXED HOOK	NF NO FITTING
SL101B-3	500	3/8	2.3	3.7	6.1	0.6	1.75	1.9	1.2	1.2	1.2	1
SL101B-4	1000	1/2	2.8	4.6	7.5	0.7	2.25	2.2	2.3	2.3	2.3	1.5
SL101B-5	1200	5/8	3.5	5.7	9.2	1.0	3.0	3.1	4	4	4	3
SL101B-6	1800	3/4	4.1	6.9	10.5	1.1	3.5	3.1	5	5	5	4
SL101B-8	2800	7/8 - 1	5.2	8.1	12.7	1.3	4.75	3.8	13	13	13	11
SL101B-10	4000	1 1/8	6.6	10.8	16.0	1.5	6.0	4.0	18	18	18	12
SL101B-12	5000	1 1/4	8.5	12.8	19.3	1.7	8.0	4.7	30	30	30	23

- Blocks built to 4:1 Design Factor
 - Blocks made with Sheave bronze bushings to SAE40 specifications
 - All accessories are forged
 - Blocks made with Santa Maria Hardwood, which has properties that are favorable for use in wood shell blocks
 - Dimensions shown represent current models and are subject to change
 - Blocks shown are standard models
 - Custom models available upon request
- See our warnings & application instructions

BLOCKS

REGULAR WOOD DOUBLE SHEAVE BLOCK



NO FITTING (NF)

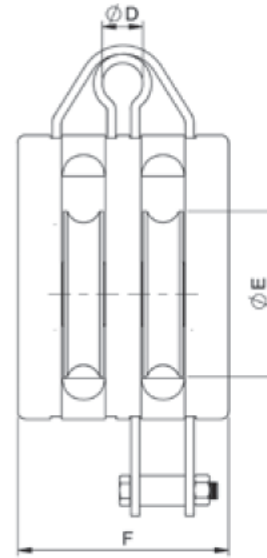

SHACKLE (S)



SWIVEL HOOK (SH)



FIXED HOOK (H)

MODEL NO.	WLL LBS	ROPE	DIMENSIONS (MM)						WEIGHT (LBS)			
									S	SH	H	NF
			ØR	A	B	C	D	ØE	F	SHACKLE	SWIVEL HOOK	FIXED HOOK
SL102B-3	800	3/8	2.3	3.7	6.1	0.7	1.75	3.0	1.9	1.9	1.9	1.6
SL102B-4	1400	1/2	2.8	4.6	7.4	0.8	2.25	3.6	3.5	3.5	3.5	2.8
SL102B-5	1800	5/8	3.5	5.7	9.4	1.0	3.0	4.8	6.5	6.5	6.5	5
SL102B-6	2500	3/4	4.1	6.9	10.6	1.0	3.5	5.0	8	8	8	7
SL102B-8	3800	7/8 - 1	5.2	8.1	13.5	1.2	4.75	6.1	16	16	16	14
SL102B-10	6000	1 1/8	6.6	10.8	16.4	1.7	6.0	6.6	27	27	27	22
SL102B-12	8000	1 1/4	8.5	12.8	20.4	2.0	8.0	7.9	49	49	49	42

- Blocks built to 4:1 Design Factor
- Blocks made with Sheave bronze bushings to SAE40 specifications
- All accessories are forged
- Blocks made with Santa Maria Hardwood, which has properties that are favorable for use in wood shell blocks
- Dimensions shown represent current models and are subject to change
- Blocks shown are standard models
- Custom models available upon request

See our warnings & application instructions

BLOCKS

REGULAR WOOD TRIPLE SHEAVE BLOCK



NO FITTING (NF)

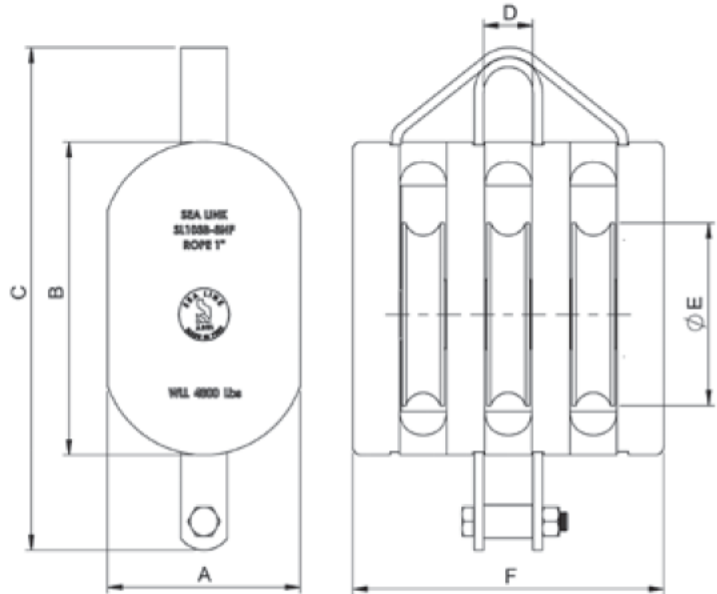

SHACKLE (S)



SWIVEL HOOK (SH)



FIXED HOOK (H)

MODEL NO.	WLL LBS	ROPE ØR	DIMENSIONS (MM)						WEIGHT (LBS)			
									S	SH	H	NF
			SHACKLE	SWIVEL HOOK	FIXED HOOK	NO FITTING						
SL103B-3	1200	3/8	2.3	3.7	6.1	0.7	1.75	4.2	2.3	2.3	2.3	2.0
SL103B-4	1800	1/2	2.8	4.6	7.6	0.8	2.25	5.0	4	4	4	3.4
SL103B-5	2400	5/8	3.5	5.7	9.4	1.0	3.0	6.6	8	8	8	6.6
SL103B-6	3200	3/4	4.1	6.9	11.0	1.3	3.5	7.0	10	10	10	9
SL103B-8	4800	7/8 - 1	5.2	8.1	13.0	1.4	4.75	8.3	20	20	20	18
SL103B-10	8000	1 1/8	6.6	10.8	16.3	1.6	6.0	9.1	34	34	34	29
SL103B-12	10000	1 1/4	8.5	12.8	20.2	1.9	8.0	11.7	63	63	63	56

- Blocks built to 4:1 Design Factor
 - Blocks made with Sheave bronze bushings to SAE40 specifications
 - All accessories are forged
 - Blocks made with Santa Maria Hardwood, which has properties that are favorable for use in wood shell blocks
 - Dimensions shown represent current models and are subject to change
 - Blocks shown are standard models
 - Custom models available upon request
- See our warnings & application instructions

EXTRA HEAVY WOOD SHELL SINGLE BLOCK



NO FITTING (NF)

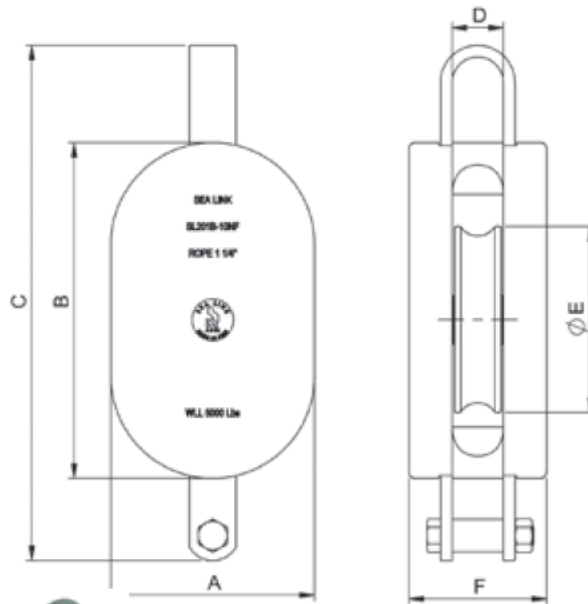

SHACKLE (S)



SWIVEL HOOK (SH)



FIXED HOOK (H)

MODEL NO.	WLL LBS	ROPE ØR	DIMENSIONS (MM)						WEIGHT (LBS)			
									S	SH	H	NF
			A	B	C	D	ØE	F	SHACKLE	SWIVEL HOOK	FIXED HOOK	NO FITTING
SL201B-6	2000	3/4	4.1	6.9	10.4	1.3	3.5	3.7	5.5	5.5	5.5	4
SL201B-8	3300	1 1/8	5.3	8.7	13.8	1.5	4.75	4.2	13	13	13	10
SL201B-10	5000	1 1/4	6.6	10.8	16.6	1.7	6.0	4.4	22	22	22	17
SL201B-12	6800	1 1/2	8.5	12.8	21.0	1.9	8.0	5.2	37	37	37	28
SL201B-14	9600	1 3/4	10.2	16.3	25.6	2.2	9.5	5.8	59	59	59	46
SL201B-16	12000	2	11.7	18.7	29.6	2.7	11.0	6.7	82	82	82	65

- Blocks built to 4:1 Design Factor.
- Blocks made with Bronze Bushed sheaves to SAE40 specifications.
- Available with self-lubricating graphite bronze sheave bushing per ASTM B438.
- All accessories are forged.
- Blocks made with Santa Maria Hardwood, which has properties that are favorable for use in wood shell blocks.
- Dimensions shown represent current models and are subject to change.
- Blocks shown here are standard models.
- Custom models available upon request.

See our warnings & application instructions

EXTRA HEAVY WOOD SHELL DOUBLE BLOCK



NO FITTING (NF)

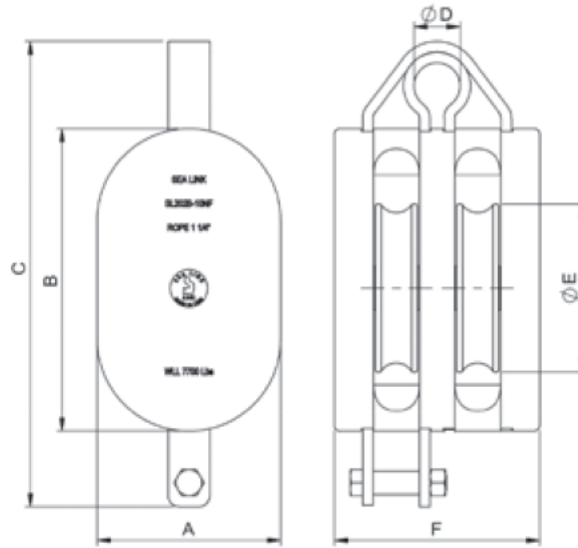

SHACKLE (S)



SWIVEL HOOK (SH)



FIXED HOOK (H)

MODEL NO.	WLL LBS	ROPE ØR	DIMENSIONS (MM)						WEIGHT (LBS)			
									S	SH	H	NF
			A	B	C	D	ØE	F	SHACKLE	SWIVEL HOOK	FIXED HOOK	NO FITTING
SL202B-6	3300	3/4	4.1	6.9	10.7	1.0	3.5	5.8	8	8	8	7
SL202B-8	5100	1 1/8	5.3	8.7	14.8	1.5	4.75	6.8	20	20	20	17
SL202B-10	7700	1 1/4	6.6	10.8	16.6	1.7	6.0	7.4	34	34	34	29
SL202B-12	10600	1 1/2	8.5	12.8	21.0	2.0	8.0	8.4	59	59	59	49
SL202B-14	15000	1 3/4	10.2	16.3	25.6	2.2	9.5	9.4	96	96	96	84
SL202B-16	19000	2	11.7	18.7	30.1	2.2	11.0	11.2	132	132	132	114

- Blocks built to 4:1 Design Factor.
 - Blocks made with Bronze Bushed sheaves to SAE40 specifications.
 - Available with self-lubricating graphite bronze sheave bushing per ASTM B438.
 - All accessories are forged.
 - Blocks made with Santa Maria Hardwood, which has properties that are favorable for use in wood shell blocks.
 - Dimensions shown represent current models and are subject to change.
 - Blocks shown here are standard models.
 - Custom models available upon request.
- See our warnings & application instructions

EXTRA HEAVY WOOD SHELL TRIPLE BLOCK



NO FITTING (NF)

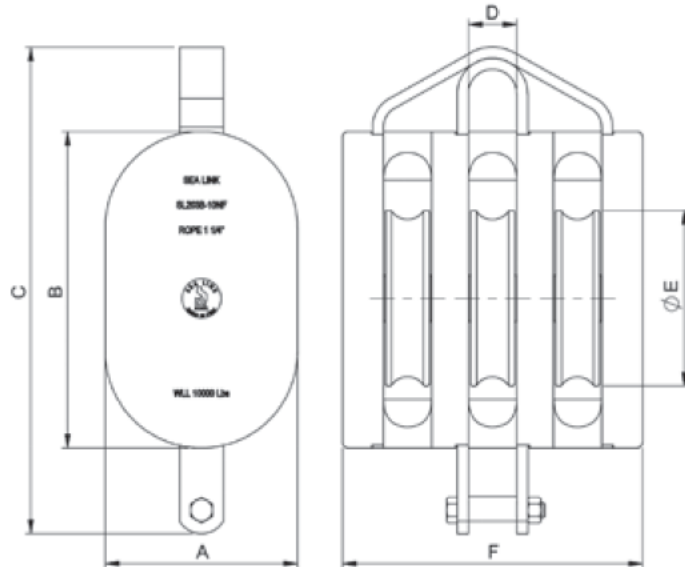

SHACKLE (S)



SWIVEL HOOK (SH)



FIXED HOOK (H)

MODEL NO.	WLL LBS	ROPE ØR	DIMENSIONS (MM)						WEIGHT (LBS)			
									S	SH	H	NF
			SHACKLE	SWIVEL HOOK	FIXED HOOK	NO FITTING						
SL203B-6	4000	3/4	4.1	6.9	10.7	1.3	3.5	8.0	11	11	11	9
SL203B-8	7000	1 1/8	5.3	8.7	14.8	1.3	4.75	9.3	25	25	25	22
SL203B-10	10000	1 1/4	6.6	10.8	16.6	1.7	6.0	10.3	43	43	43	37
SL203B-12	14000	1 1/2	8.5	12.8	20.7	2.0	8.0	11.7	73	73	73	63
SL203B-14	20000	1 3/4	10.2	16.3	25.6	2.2	9.5	13.1	114	114	114	102
SL203B-16	24000	2	11.7	18.7	30.1	2.7	11.0	15.7	166	166	166	149

- Blocks built to 4:1 Design Factor.
 - Blocks made with Bronze Bushed sheaves to SAE40 specifications.
 - Available with self-lubricating graphite bronze sheave bushing per ASTM B438.
 - All accessories are forged.
 - Blocks made with Santa Maria Hardwood, which has properties that are favorable for use in wood shell blocks.
 - Dimensions shown represent current models and are subject to change.
 - Blocks shown here are standard models.
 - Custom models available upon request.
- See our warnings & application instructions

EXTRA HEAVY NON-TOPPLING WOOD SHELL BLOCK SINGLE



NO FITTING (NF)
NO BECKET (NB)

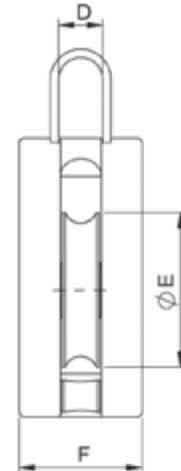

SHACKLE (S)
NO BECKET (NB)



SHACKLE (S)

MODEL NO.	WLL LBS	ROPE ØR	DIMENSIONS (MM)							WEIGHT (LBS)	
			A	B	C	D	ØE	F	SHACKLE	NF	S
										NO FITTING	SHACKLE
SL201B-8 NT	3300	1 1/8	9.1	8.6	11.3	1.3	4.8	3.8	7/8	10	13
SL201B-10 NT	5000	1 1/4	11.8	8.7	14.8	1.3	4.75	9.3	1	18	23
SL201B-12 NT	6800	1 1/2	6.6	10.8	16.6	1.7	6.0	10.3	1 1/8	36	44

- Blocks built to 4:1 Design Factor.
- Blocks made with Bronze Bushed sheaves to SAE40 specifications.
- Available with self-lubricating graphite bronze sheave bushing per ASTM B438.
- All accessories are forged.
- Blocks made with Santa Maria Hardwood, which has properties that are favorable for use in wood shell blocks.
- Dimensions shown represent current models and are subject to change.
- Blocks shown here are standard models.
- Custom models available upon request.

See our warnings & application instructions

EXTRA HEAVY NON-TOPPLING WOOD SHELL BLOCK DOUBLE



NO FITTING (NF)
NO BECKET (NB)

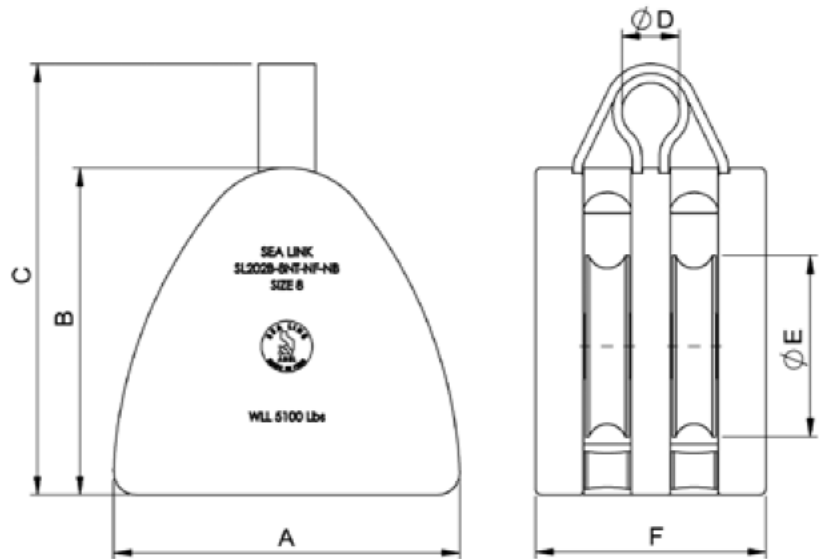

SHACKLE (S)
NO BECKET (NB)

SHACKLE (S)

MODEL NO.	WLL LBS	ROPE ØR	DIMENSIONS (MM)							WEIGHT (LBS)	
			A	B	C	D	ØE	F	SHACKLE	NF	S
										NO FITTING	SHACKLE
SL202B-8 NT	5100	1 1/8	9.1	8.6	11.6	1.5	4.8	6.1	7/8	17	21
SL202B-10 NT	7700	1 1/4	11.8	11.2	15.2	1.6	6.3	7.2	1	33	39
SL202B-12 NT	10600	1 1/2	15.4	14.4	19.5	1.7	8.0	8.4	1 1/8	64	70

- Blocks built to 4:1 Design Factor.
- Blocks made with Bronze Bushed sheaves to SAE40 specifications.
- Available with self-lubricating graphite bronze sheave bushing per ASTM B438.
- All accessories are forged.
- Blocks made with Santa Maria Hardwood, which has properties that are favorable for use in wood shell blocks.
- Dimensions shown represent current models and are subject to change.
- Blocks shown here are standard models.
- Custom models available upon request.

See our warnings & application instructions

EXTRA HEAVY NON-TOPPLING WOOD SHELL BLOCK TRIPLE



NO FITTING (NF)
NO BECKET (NB)

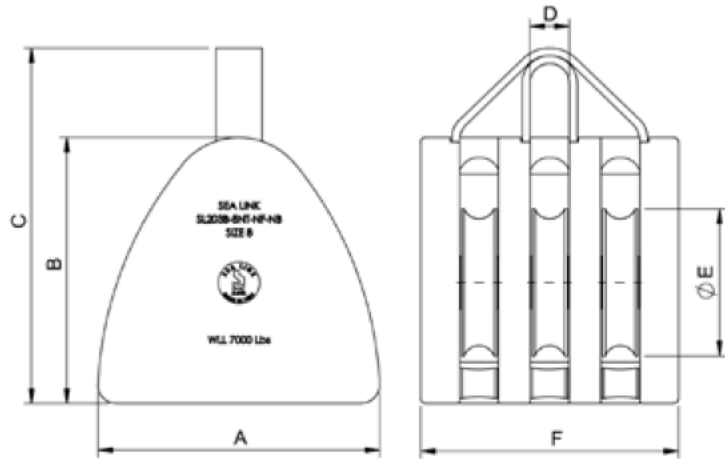

SHACKLE (S)
NO BECKET (NB)



SHACKLE (S)

MODEL NO.	WLL LBS	ROPE ØR	DIMENSIONS (MM)							WEIGHT (LBS)	
			A	B	C	D	ØE	F	SHACKLE	NF	S
										NO FITTING	SHACKLE
SL203B-8 NT	7000	1 1/8	9.1	8.6	11.6	1.5	4.8	8.3	7/8	22	26
SL203B-10 NT	10000	1 1/4	11.8	11.2	15.2	1.7	6.3	10.0	1	44	48
SL203B-12 NT	14000	1 1/2	15.4	14.4	19.5	1.9	8.0	11.7	1 1/8	80	88

- Blocks built to 4:1 Design Factor.
- Blocks made with Bronze Bushed sheaves to SAE40 specifications.
- Available with self-lubricating graphite bronze sheave bushing per ASTM B438.
- All accessories are forged.
- Blocks made with Santa Maria Hardwood, which has properties that are favorable for use in wood shell blocks.
- Dimensions shown represent current models and are subject to change.
- Blocks shown here are standard models.
- Custom models available upon request.

See our warnings & application instructions