

Motorized Rotating Crane Hooks

Model 250 - Motorized Rotating Crane Hook

Motorized Rotating Crane Hooks make rotating loads on the crane hook easy for the operator. Each unit is custom designed per your requirements.



PRODUCT FEATURES:

- Sheave pin includes lubrication fittings.
- External lubrication on heavy duty thrust bearing.
- Heavy duty worm gear reducer.
- Chain and sprocket final drive.
- Drive protection includes slip clutch.
- Designed for ease of maintenance.
- 360 degree continuous rotation.
- AC power.

PRODUCT OPTIONS:

- Pin bail type attachment.
- Clevis or lug instead of crane hook.
- Hook/drive disengagement.
- Bull gear and pinion final drive.
- Continuous rotation with electrical collector ring to operate motorized below-the-hook lifters.
- DC power.
- Mechanical stops.
- Electrical reversing motor controls.
- Integral weighing system.

Motorized Rotating Crane Hooks

Clevis Style

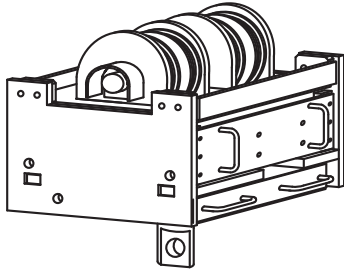

Pin Bail

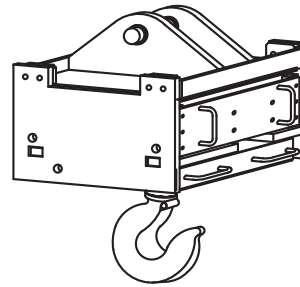

Motorized Rotating Crane Hook Application Evaluation

1. CMAA Crane Duty Class (A, B, C, D, E, F): _____
2. Capacity of crane: _____
3. Number of sheaves: _____
4. Sheave diameter: _____
5. Sheave spacing (A): _____ (X): _____
6. Type of sheave bearings: _____
7. Wire rope diameter: _____
8. Maximum degree of rotation required: _____
9. Will a motorized grab be suspended from the hook?
 Yes No
10. Operating voltage: _____
11. Headroom Dimension: _____

12. Describe load to be rotated:
 - a. Weight _____
 - b. Length _____
 - c. Width _____
 - d. Height _____
 - e. Shape _____
13. Will hook be exposed to a high temperature environment? Yes No
14. Will hook be outdoors? Yes No
15. Operation controlled from:
 Cab Pendant Remote
16. Load scale required? Yes No

Describe requirements: _____

17. Options required: _____

Contact: _____

Company: _____

Address: _____

City, State, Zip: _____

Phone: _____

Fax: _____

Email: _____

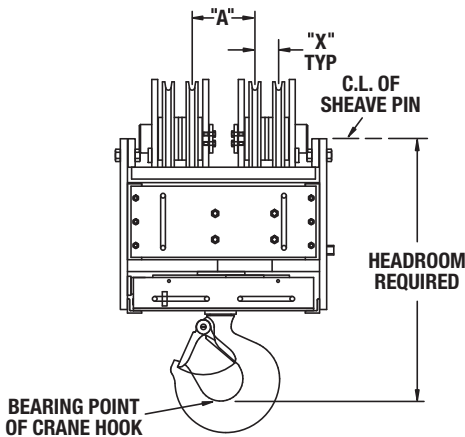

For a price quote on your specific application, please complete the above form and fax to **TORQHOIST @ 216-292-5551** or you can complete this form online at